

BFB 51 x 51 x 15 MM SERIES

DIMENSIONS DRAWING

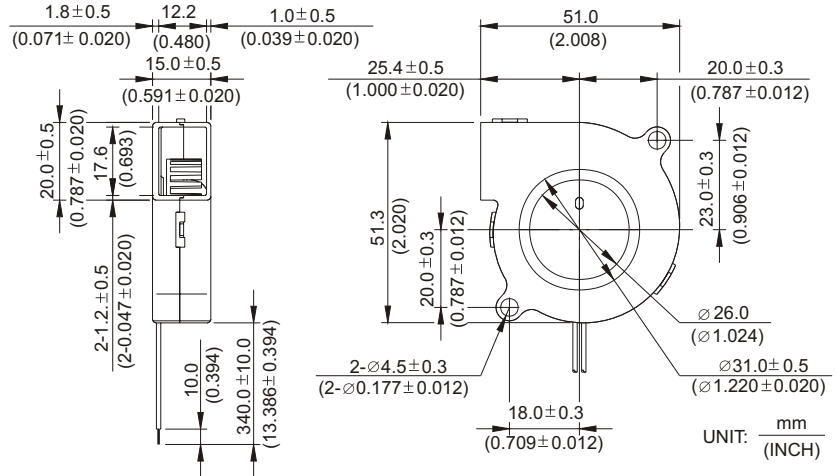

- * Bearing Type
Ball Bearings
- * Material
Impeller & Frame : Plastic (UL 94V-0)
- * Lead Wires :
UL 1061 AWG #26 Or Equivalent
Red Wire Positive (+)
Black Wire Negative (-)
- * Weight : 28g (0.99 oz)

P & Q CURVE (AT RATED VOLTAGE)

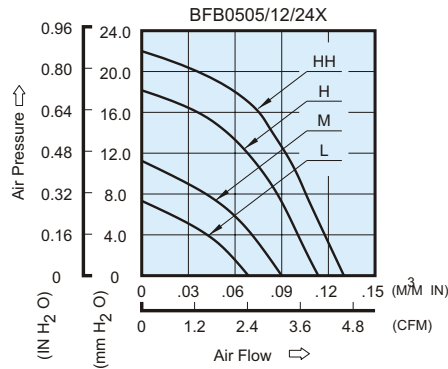

MODEL		Rated Voltage	Operating Voltage Range	Rated Current	Rated Input Power	Speed	Maximum Air Flow		Maximum Air Pressure		Noise
PART NO.	FUNCTION	VDC	VDC	Amp	Watt	R.P.M.	m ³ /min	CFM	mmH ₂ O	IN H ₂ O	dB-A
BFB0505L	-R00/ -F00	5	4.0 to 5.5	0.14	0.70	3500	0.070	2.47	7.00	0.276	26.5
BFB0512L	-R00/ -F00	12	10.0 to 13.8	0.07	0.84						
BFB0524L	-R00/ -F00	24	14.0 to 27.6	0.05	1.20						
BFB0505M	-R00/ -F00	5	4.0 to 5.5	0.33	1.65	4500	0.090	3.18	11.00	0.433	32.5
BFB0512M	-R00/ -F00	12	10.0 to 13.8	0.10	1.20						
BFB0524M	-R00/ -F00	24	14.0 to 27.6	0.07	1.68						
BFB0512H	-R00/ -F00	12	10.0 to 13.8	0.16	1.92	5500	0.110	3.88	18.00	0.709	38.0
BFB0524H	-R00/ -F00	24	14.0 to 27.6	0.09	2.16						
BFB0512HH	-R00/ -F00	12	10.0 to 13.8	0.21	2.52						
BFB0524HH	-R00/ -F00	24	14.0 to 27.6	0.11	2.64	6500	0.130	4.59	22.00	0.866	45.0

* Function type is optional.
 * The max. air flow and the speed are measured in free air ; max. air pressure is measured at zero air flow.
 * Noise is measured in anechoic chamber in free air, one meter from intake side.
 * All readings are typical values at rated voltage.
 * Specifications are subject to change without notice.