

mm inch

FEATURES

- 40 A rating at 85°C 185°F
- ISO type terminals
- High shock resistance for drop test requirements (2 meters 6.6 feet)
- Low temperature rise — all current carrying material is copper.
- Plug-in and PC board type

SPECIFICATIONS

Contact

(1) Standard type (12V coil voltage)

Arrangement		1 Form A	1 Form C	High contact capacity (1 Form A)
Rating	Nominal switching capacity	40 A 14 V DC	N.O.: 40 A 14 V DC N.C.: 30 A 14 V DC	70 A 14 V DC (at 20°C 68°F) 50 A 14 V DC (at 85°C 185°F)
	Max. switching current (at 85°C 185°F)	N.O.: 40 A 14 V DC	N.O.: 40 A 14 V DC N.C.: 30 A 14 V DC	N.O.: 40 A 14 V DC
Initial contact resistance (By voltage drop 6 V DC 1 A)		Max. 15mΩ		
Contact material		Silver alloy		
Min. switching capacity#1		1 A 12 V DC (12 V DC), 1 A 24 V DC (24 V DC),		
Expected life	Mechanical (at 120 cpm)	Min. 10 ⁶		
	Electrical (at rated load)	Flux-resistant type: Min. 10 ^{5*1} Sealed type: Min. 5 × 10 ⁴		

#1 This value can change due to the switching frequency, environmental conditions, and desired reliability level, therefore it is recommended to check this with the actual load.

(2) Standard type (24V coil voltage)

Arrangement		1 Form A	1 Form C	High contact capacity (1 Form A)
Rating	Nominal switching capacity	20 A 28V DC	N.O.: 20 A 28 V DC N.C.: 10 A 28 V DC	20 A 28V DC
	Max. switching current (at 85°C 185°F)	20 A 28 V DC	N.O.: 20 A 28 V DC N.C.: 10 A 28 V DC	20 A 28 V DC

*1 All other specifications are the same as those of standard type (12V coil voltage)

(3) Heat resistant type (12V, 24V coil voltage)

Type		12V coil voltage		24V coil voltage	
Arrangement		1 Form A	1 Form C	1 Form A	1 Form C
Rating	Nominal switching capacity	40 A 14V DC	N.O.: 40 A 14 V DC N.C.: 30 A 14 V DC	20 A 28 V DC	N.O.: 20 A 28 V DC N.C.: 10 A 28 V DC
	Max. switching current (at 85°C 185°F)	40 A 14 V DC	N.O.: 40 A 14 V DC N.C.: 30 A 14 V DC	20 A 28V DC	N.O.: 20 A 28 V DC N.C.: 10 A 28 V DC

*1 All other specifications are the same as those of standard type (12V coil voltage)

Coil

Arrangement	Coil voltage	Nominal operating power
1 Form A, 1 Form C	12V DC	1.4W
	24V DC	1.8W
High contact capacity (1 Form A)	12V DC	1.8W
	24V DC	1.8W

Characteristics

Max. operating speed (at rated load)		15 cpm
Initial insulation resistance*2		Min. 20 MΩ (at 500 V DC)
Initial breakdown voltage*3	Between open contacts	500 Vrms for 1 min.
	Between contacts and coil	500 Vrms for 1 min.
Operate time*4 (at nominal voltage)		Max. 15 ms (Initial)
Release time (without diode)*4 (at nominal voltage)		Max. 15 ms (Initial)
Shock resistance	Functional	Min. 200 m/s ² {20 G}
	Destructive	Min. 1,000 m/s ² {100 G}
Vibration resistance	Functional	10 Hz to 500 Hz, Min. 44.1m/s ² {4.5G}
	Functional*5	10 Hz to 2,000 Hz, Min. 44.1m/s ² {4.5G}
Conditions for operation, transport and storage*6 (Not freezing and condensing at low temperature)	Ambient temp.	-40°C to +85°C -40°F to +185°F (Heat resistant type: -40°C to +125°C -40°F to +257°F)
	Humidity	5% R.H. to 85% R.H.
Mass		Approx. 33 g 1.16 oz

Remarks

*1 At nominal switching capacity, operating frequency: 2s ON, 2s OFF

*2 Measurement at same location as "Initial breakdown voltage" section

*3 Detection current: 10 mA

*4 Excluding contact bounce time

*5 Time of vibration for each direction; X, Y, Z direction: 4 hours



*6 Refer to 6. Conditions for operation, transport and storage mentioned in AMBIENT ENVIRONMENT

TYPICAL APPLICATIONS

- Head lights
- Starters
- ABS
- Head Lamp
- Air conditioner
- Tractor, Combine

ORDERING INFORMATION

CB 1 F — T — M — 12 V				
Contact arrangement	Protective construction	Heat resistant of types	Mounting classification	Coil voltage (DC)
1a: 1 Form A 1: 1 Form C 1aH: High contact capacity (1 Form A)	Nil: Sealed type F: Flux-resistant type	Nil: Standard type T: Heat resistant type*1	Nil: Plug-in type P: PC board type M: Bracket type	12, 24 V

Note: Bulk package: 50 pcs.; Case: 200 pcs.

*1 Heat resistant type with high contact capacity is not available.
(See "2. Heat resistant type in TYPES" page 412)

TYPES

1. Standard type

Contact arrangement	Mounting classification	Coil voltage, V DC	Part No.	
			Sealed type	Flux-resistant type
1 Form A	PC board type	12V	CB1a-P-12V	CB1aF-P-12V
		24V	CB1a-P-24V	CB1aF-P-24V
	Plug-in type	12V	CB1a-12V	CB1aF-12V
		24V	CB1a-24V	CB1aF-24V
	Bracket type	12V	CB1a-M-12V	CB1aF-M-12V
		24V	CB1a-M-24V	CB1aF-M-24V
1 Form C	PC board type	12V	CB1-P-12V	CB1F-P-12V
		24V	CB1-P-24V	CB1F-P-24V
	Plug-in type	12V	CB1-12V	CB1F-12V
		24V	CB1-24V	CB1F-24V
	Bracket type	12V	CB1-M-12V	CB1F-M-12V
		24V	CB1-M-24V	CB1F-M-24V
High contact capacity (1 Form A)	Plug-in type	12V	CB1aH-12V	CB1aHF-12V
		24V	CB1aH-24V	CB1aHF-24V

* High contact capacity PC board type is also available. Please contact us for details.

2. Heat resistant type

Contact arrangement	Mounting classification	Coil voltage, V DC	Part No.	
			Sealed type	Flux-resistant type
1 Form A	PC board type	12V	CB1a-T-P-12V	CB1aF-T-P-12V
		24V	CB1a-T-P-24V	CB1aF-T-P-24V
	Plug-in type	12V	CB1a-T-12V	CB1aF-T-12V
		24V	CB1a-T-24V	CB1aF-T-24V
	Bracket type	12V	CB1a-T-M-12V	CB1aF-T-M-12V
		24V	CB1a-T-M-24V	CB1aF-T-M-24V
1 Form C	PC board type	12V	CB1-T-P-12V	CB1F-T-P-12V
		24V	CB1-T-P-24V	CB1F-T-P-24V
	Plug-in type	12V	CB1-T-12V	CB1F-T-12V
		24V	CB1-T-24V	CB1F-T-24V
	Bracket type	12V	CB1-T-M-12V	CB1F-T-M-12V
		24V	CB1-T-M-24V	CB1F-T-M-24V

COIL DATA (at 20°C 68°F)

Contact arrangement	Nominal voltage, V DC	Pick-up voltage, V DC*	Drop-out voltage, V DC	Nominal current, mA	Coil resistance, Ω	Nominal operating power, W	Usable voltage range, V DC
1 Form A 1 Form C	12	Max. 3 to 7	Min. 1.2 to 4.2	117±10%	103±10%	1.4	10 to 16
	24	Max. 6 to 14	Min. 2.4 to 8.4	75±10%	320±10%	1.8	20 to 32
High contact capacity (1 Form A)	12	Max. 3 to 7	Min. 1.2 to 4.2	150±10%	80±10%	1.8	10 to 16

* Other pick-up voltage types are also available. Please contact us for details.

DIMENSIONS

mm inch

1. PC board type

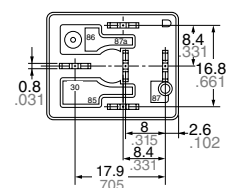
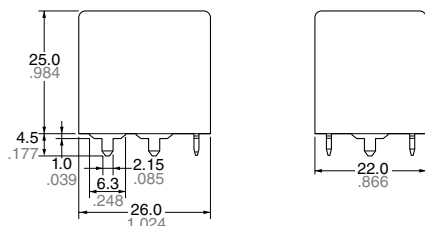

Schematic (Bottom view)

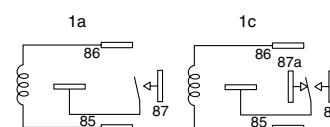

Dimension:

Max. 1mm .039 inch:
1 to 3mm .039 to .118 inch:
Min. 3mm .118 inch:

General tolerance

±0.1 ±.004
±0.2 ±.008
±0.3 ±.012

2. Plug-in type

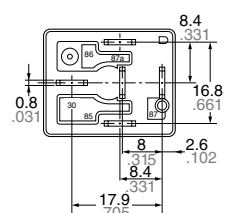
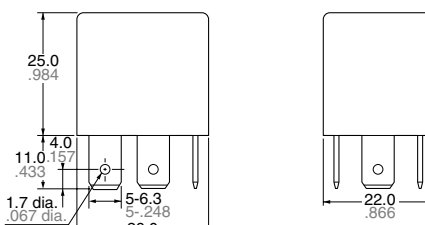

Schematic (Bottom view)

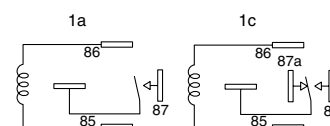

Dimension:

Max. 1mm .039 inch:
1 to 3mm .039 to .118 inch:
Min. 3mm .118 inch:

General tolerance

±0.1 ±.004
±0.2 ±.008
±0.3 ±.012

3. Bracket type

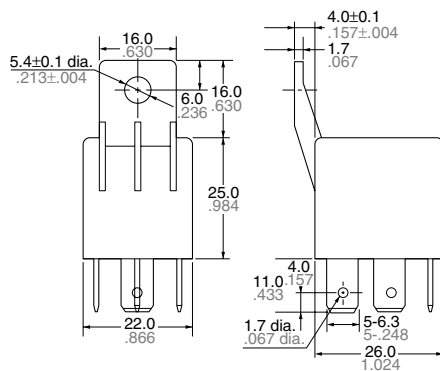

Schematic (Bottom view)

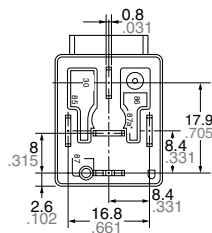
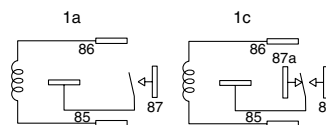

Dimension:	General tolerance
Max. 1mm .039 inch:	±0.1 ±.004
1 to 3mm .039 to .118 inch:	±0.2 ±.008
Min. 3mm .118 inch:	±0.3 ±.012

4. High contact capacity type (Plug-in terminal type)

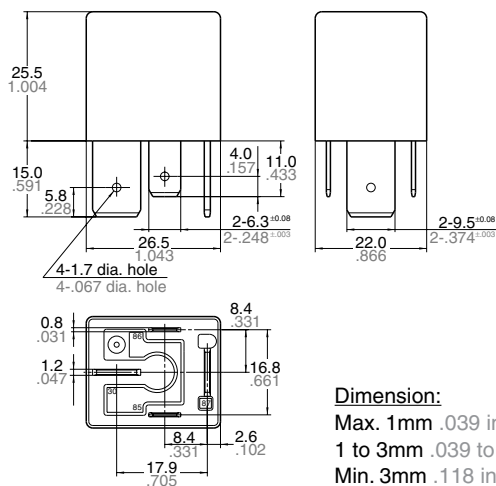

Schematic (Bottom view)

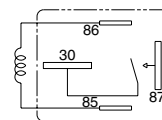

Dimension:	General tolerance
Max. 1mm .039 inch:	±0.1 ±.004
1 to 3mm .039 to .118 inch:	±0.2 ±.008
Min. 3mm .118 inch:	±0.3 ±.012

REFERENCE DATA

CB (Standard type)

1. Coil temperature rise

Sample: CB1aF-P-12V, 3pcs.
 Measured portion: Inside the coil
 Contact carrying current: 40A
 Ambient temperature: 85°C 185°F

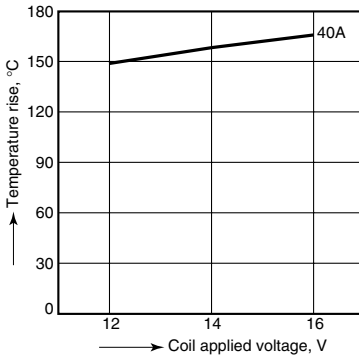

2. Max. switching capability (Resistive load) (Standard type)

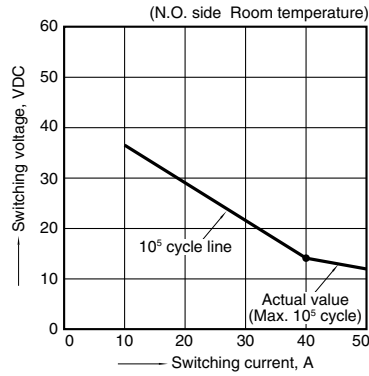

3. Ambient temperature and operating temperature range (Standard type)

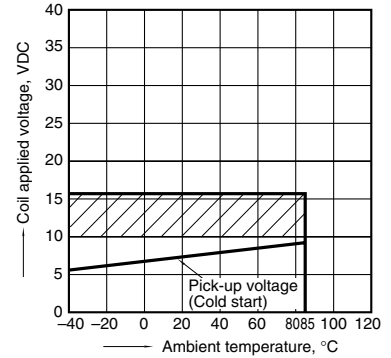

4. Distribution of pick-up and drop-out voltage

Sample: CB1-P-12V, 42pcs.

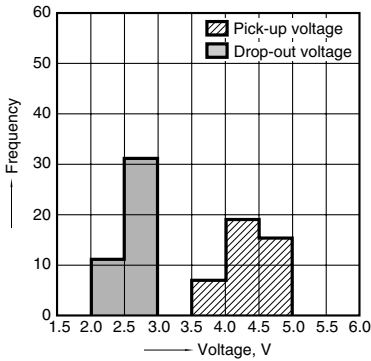

5. Distribution of operate and release time

Sample: CB1-P-24V, 42pcs.

* Without diode

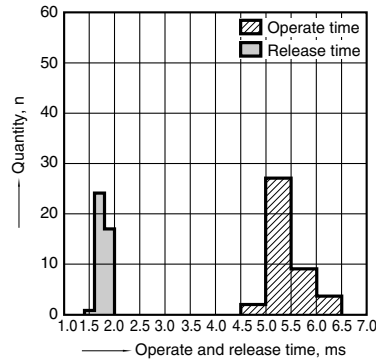

6-(1). Electrical life test (Motor free)

Sample: CB1F-12V, 5pcs.
 Load: 25A 14V DC, motor free actual load
 Switching frequency: (ON:OFF = 1s:9s)
 Ambient temperature: Room temperature
 Circuit

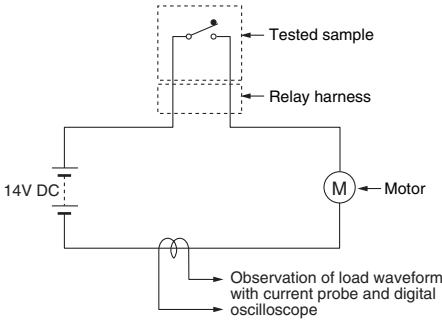

Load current waveform

Inrush current: 80A, Steady current: 25A,

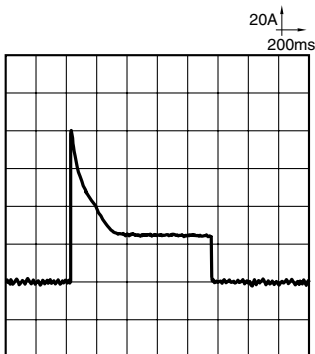

Change of pick-up and drop-out voltage

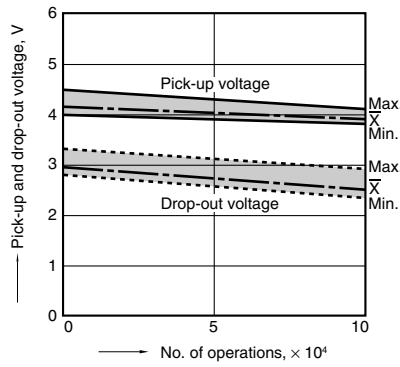

Change of contact resistance

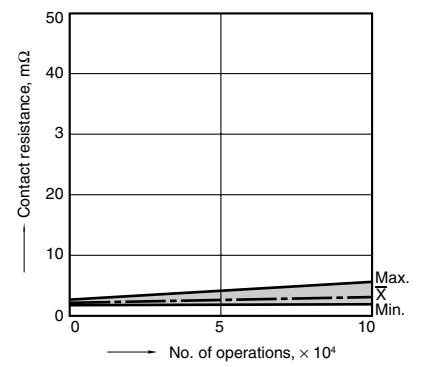

6-(2). Electrical life test (Lamp load)

Sample: CB1F-12V, 5pcs.
 Load: 45/65Wx5 parallel, 14V DC, halogen lamp actual load
 Switching frequency: (ON:OFF = 1s:8s)
 Ambient temperature: Room temperature
 Circuit

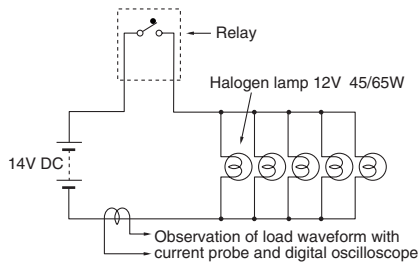

Load current waveform

Inrush current: 100A, Steady current: 20A,

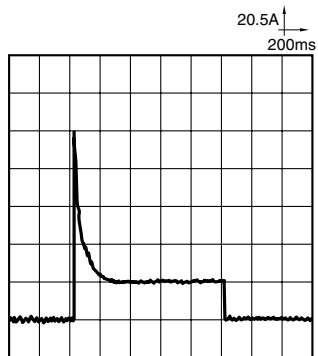

Change of pick-up and drop-out voltage

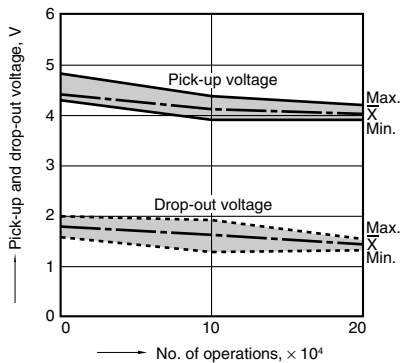

Change of contact resistance

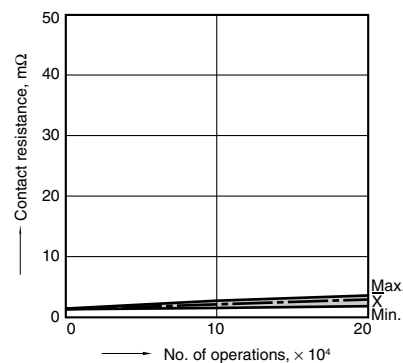

CB (High capacity type)

1. Max. switching capability
 (High capacity type)

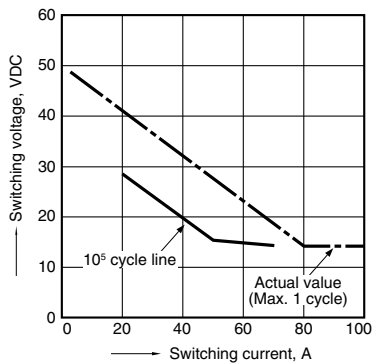

2. Ambient temperature and operating temperature range
 (High capacity type)

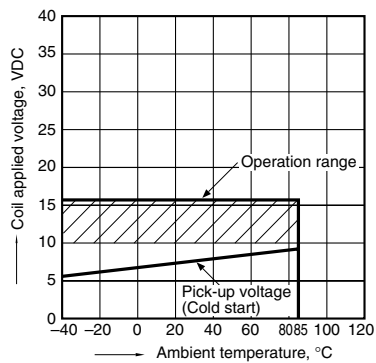

3. Distribution of pick-up and drop-out voltage
 Sample: CB1aHF-12V, 53pcs.

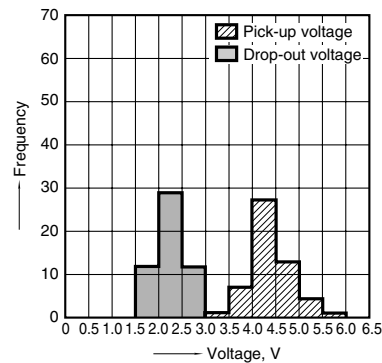

4. Distribution of operate and release time
 Sample: CB1aHF-12V, 53pcs.

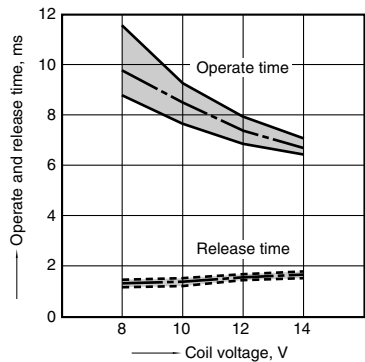

5. Contact resistance
 Sample: CB1aHF-12V, 53pcs.
 (By voltage drop 6V DC 1A)

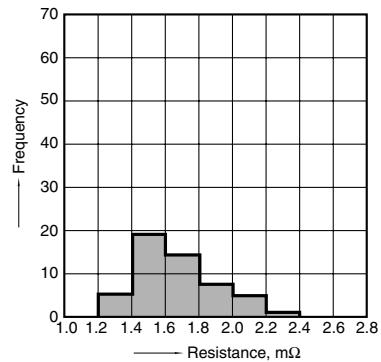

6-(1). Electrical life test (Motor free)

Sample: CB1aH-12V, 3pcs.
 Load: Inrush current: 64A/Steady current: 35A
 Fan motor actual load (motor free) 12V DC
 Switching frequency: (ON:OFF = 3s:7s)
 Ambient temperature: Room temperature
 Circuit

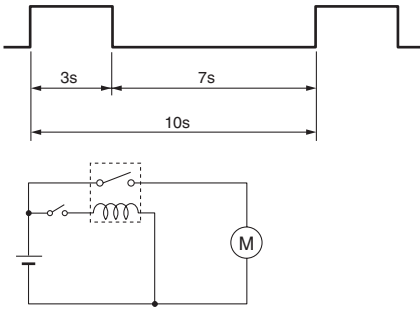

Load current waveform

Inrush current: 64A, Steady current: 35A,

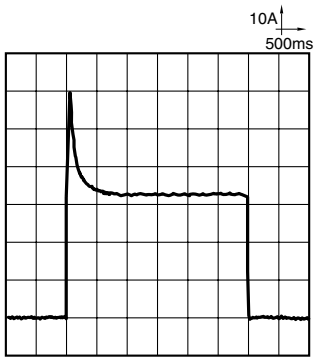

Change of pick-up and drop-out voltage

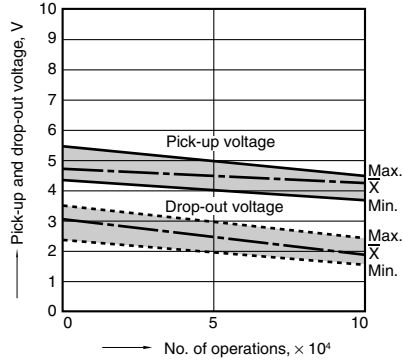

Change of contact resistance

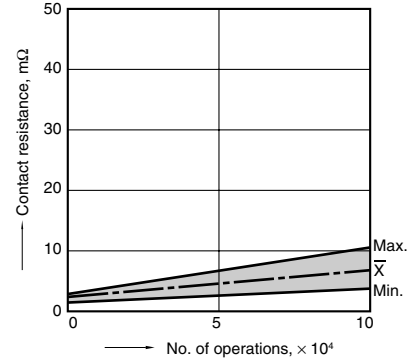

6-(2). Electrical life test (Motor lock)

Sample: CB1aH-12V, 5pcs.
 Load: 100A 14V DC
 Magnet clutch actual load (lock condition)
 Switching frequency: (ON:OFF = 1s:9s)
 Ambient temperature: Room temperature
 Circuit

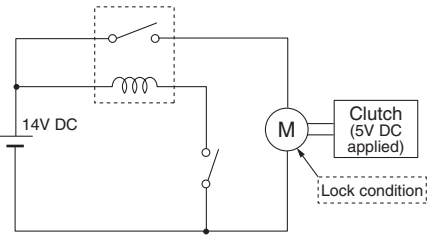

Load current waveform

100A 14V DC

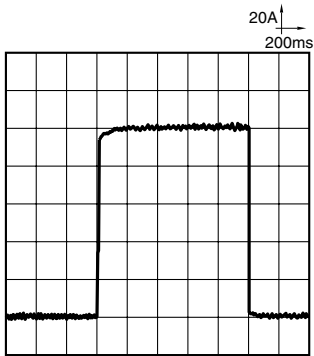

Change of pick-up and drop-out voltage

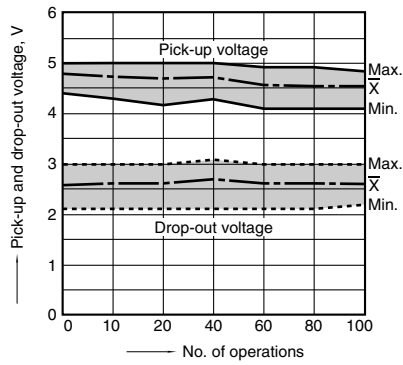

Change of contact resistance

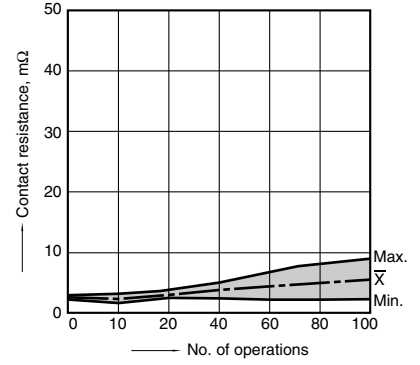

Cautions regarding the protection element

1. Part numbers without protection elements

1) 12 V models

When connecting a coil surge protection circuit to these relays, we recommend a Zener diode with a Zener voltage of 24 V or higher, or a resistor (680Ω to 1,000Ω). When a diode is connected to the coil in parallel, the release time will slow down and working life may shorten. Before use, please check the circuit and verify that the diode is not connected in parallel to the coil drive circuit.

2) 24 V models

When connecting a coil surge protection circuit to these relays, we recommend a Zener diode with a Zener voltage of 48 V or higher, or a resistor (2,800Ω to 4,700Ω).

When a diode is connected to the coil in parallel, the release time will slow down and working life may shorten. Before use, please check the circuit and verify that the diode is not connected in parallel to the coil drive circuit.

2. Part numbers with diodes

These relays use a diode in the coil surge protection element. Therefore, the release time is slower and the working life might be shorter compared to part numbers without protection elements and part numbers with resistors.

Be sure to use only after evaluating under actual load conditions.

3. Part numbers with resistors

This part number employs a resistor in the coil surge protection circuit; therefore, an external surge protection element is not required. In particular, when a diode is connected in parallel with a coil, the revert time becomes slower which could adversely affect working life. Please check the circuit and make sure that a diode is not connected in parallel with the coil drive circuit.

For Cautions for Use, see Relay Technical Information